

HT23 RTJ O / PRO



OUTSTANDING PERFORMANCE & PRODUCTIVITY

- > Very good working envelope
- > Basket load capacity 230 kg
- > Dual load 230-450 kg (option)

BEST COMFORT AND SAFETY FEELING

- > Haulotte Activ'Shield Bar 2.0 (standard on PRO)
- > Haulotte Activ'Lighting System for safe loading/unloading in conditions of low visibility (standard on PRO)
- > Quick, proportional and simultaneous movements
- > Rigid boom

MAXIMIZED TOTAL COST OF OWNERSHIP

- > Haulotte Activ'Screen diagnostic display for onboard fault & service alerts
- > Haulotte Stop Emission System automatically turns the engine off & on
- > Easy access to all components
- > Exclusive modular basket, quick and easy to repair

HT23 RTJ O / PRO

ROUGH TERRAIN
TELESCOPIC BOOMS

TECHNICAL DATA

HT23 RTJ O **HT23 RTJ PRO**
4WD/2WS **4WD/4WS**

Working height	22.5 m	
Platform height	20.5 m	
Horizontal outreach	18.3 m	
Below ground reach	4 m	
Lift capacity	230 kg - 2 pers. (option : 450 kg - 3 pers.)	
F x G Platform size	2.44 x 0.91 m	
A Length - stowed	10.4 m	
H Length - transport	7.8 m	
B Overall width	2.47 m	
C Height - stowed	2.7 m	
I Height - transport	3.3 m	
Vertical jib rotation	133° (+68/-65)	
Platform rotation	180° (+90/-90)	
Boom rotation angle	90° (+75/-15)	
Turntable rotation	360° continuous	
Tailswing	109 cm	
D Wheelbase	2.5 m	
E Ground clearance	34 cm	
Tilt	5°	
Drive speed	0.5 - 6.5 km/h	
Gradeability	40 %	
Turning radius - outside	6,3 m	3,4 m
Tyres - foam-filled	385/65 - 22.5	
Fuel tank	166 l	
Engine	Kubota 48.6 kW, stage 5 NRC: Kubota, 36.5kW, Stage 3A	
Weight	13 320 kg	13 400 kg

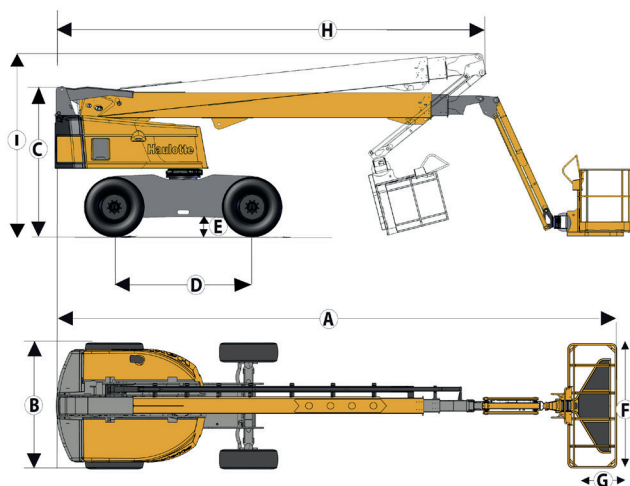

STANDARD EQUIPMENT

- > Haulotte Activ'Lighting System (standard on PRO)
- > Haulotte Activ'Shield Bar (standard on PRO)
- > Haulotte Stop Emission System
- > Haulotte Activ'Screen onboard colored monitor screen and diagnostic system
- > Universal telematics plug
- > 4 wheel drive / 2 (O) or 4 (PRO) wheel steer
- > Front oscillating axle increases stability on uneven ground
- > Proportional controls enhance comfort and safety
- > 4 simultaneous movements for maximum productivity
- > Automatic differential wheel lock increase rough terrain capacity
- > Upper control box protection cover and tool tray in ultra-solid composite
- > 230 kg load capacity unrestricted working envelope
- > Large modular basket 2.44 x 0.91 m, drop entry gate
- > Basket limitation +/- 10°
- > Prepared for power to platform 110 / 230V
- > Swing out engine tray for ease of maintenance
- > Sound and light alarm for tilt and load
- > Maximum wind speed 45 km/h
- > Rotating beacon
- > Driving alarm
- > Hour meter
- > Electric pump system and emergency descent
- > 12 V battery
- > Engine pre-heater with light indicator
- > Low fuel level indicator (upper control box)

OPTIONS AND ACCESSORIES

- > Haulotte Activ'Lighting System (O model)
- > Haulotte Activ'Shield Bar 2.0 (O model)
- > Dual load capacity 230 / 450 kg (2-3 persons)
- > Narrow modular platform 1.83 m x 0.8 m
- > Power to platform (Female plug in the basket with or without circuit-breaker 30mA)
- > Air line to platform
- > Lateral swing door entry gate
- > 3.5 kW, 6,5 kW, 12 kW (Only NA) hydraulic generator
- > Biodegradable hydraulic oil
- > 60km/h wind speed
- > Warm environment package
- > Cold weather package / Kit Arctic
- > Pipe cradle pack
- > Glazier pack
- > Working lights

